

Z36/...

Mat.: 1.0718

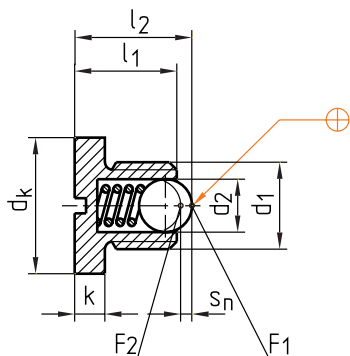

max. °C	d ₂	d _k	k	s _n	F ₁ [N]	F ₂ [N]	l ₂	d ₁	l ₁	Nr./No.
250	2,5	6	2,5	0,64	6	11,6	9,8	M 4	9	Z36/ 4x 9
	3	8	3,5	0,72	8,8	13,3	12,9	M 5	12	5x12
	3,5	10	5	0,8	11,2	15,1	15	M 6	14	6x14
	5	13		1,2	18,5	29,5	17,5	M 8	16	8x16
	6	16	6	1,6	23,9	43	22	M10	20	10x20
	8	18	7	2	35,9	59,8	24,5	M12	22	12x22

Z361/...

Mat.: 1.4305

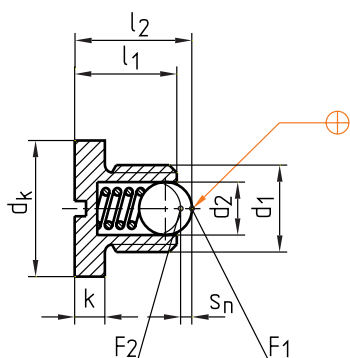

max. °C	d ₂	d _k	k	s _n	F ₁ [N]	F ₂ [N]	l ₂	d ₁	l ₁	Nr./No.
250	5	13	5	1,2	18,5	29,5	17,5	M 8	16	Z361/ 8x16
	8	18	7	2	35,9	59,8	24,5	M12	22	12x22

This is trial version
www.adultpdf.com